

34018 34018

# HEAVY DUTY BASE MACHINE FOR FOUNDATION WORK

# KOBELCO

## BM 600

Max. Lifting Capacity: 55 Metric Tons at 3.7 Meters

Max. Boom Length: 51.8 Meters

## Specifications

- A mega-powered crane equipped with precision control capability.
- Engine Speed Sensing (ESS) System makes efficient 100% use of engine power for steady, effortless operation.
- Powerful engine and strong line pull make light work of heavy-duty tasks such as diaphragm wall construction.
- Precise, full hydraulic control gives crane performance ideal for construction tasks demanding high precision.
- Powerful winch first layer maximum line pull of 17 tons, and wide, large-diameter drum with maximum rope capacity of 32 m at first layer.
- Maximum line speed of 100 m/min for main and auxiliary winches.
- Extra hydraulic outlets provided to power additional foundation construction machinery. (opt.)

## General Dimensions

Unit: mm

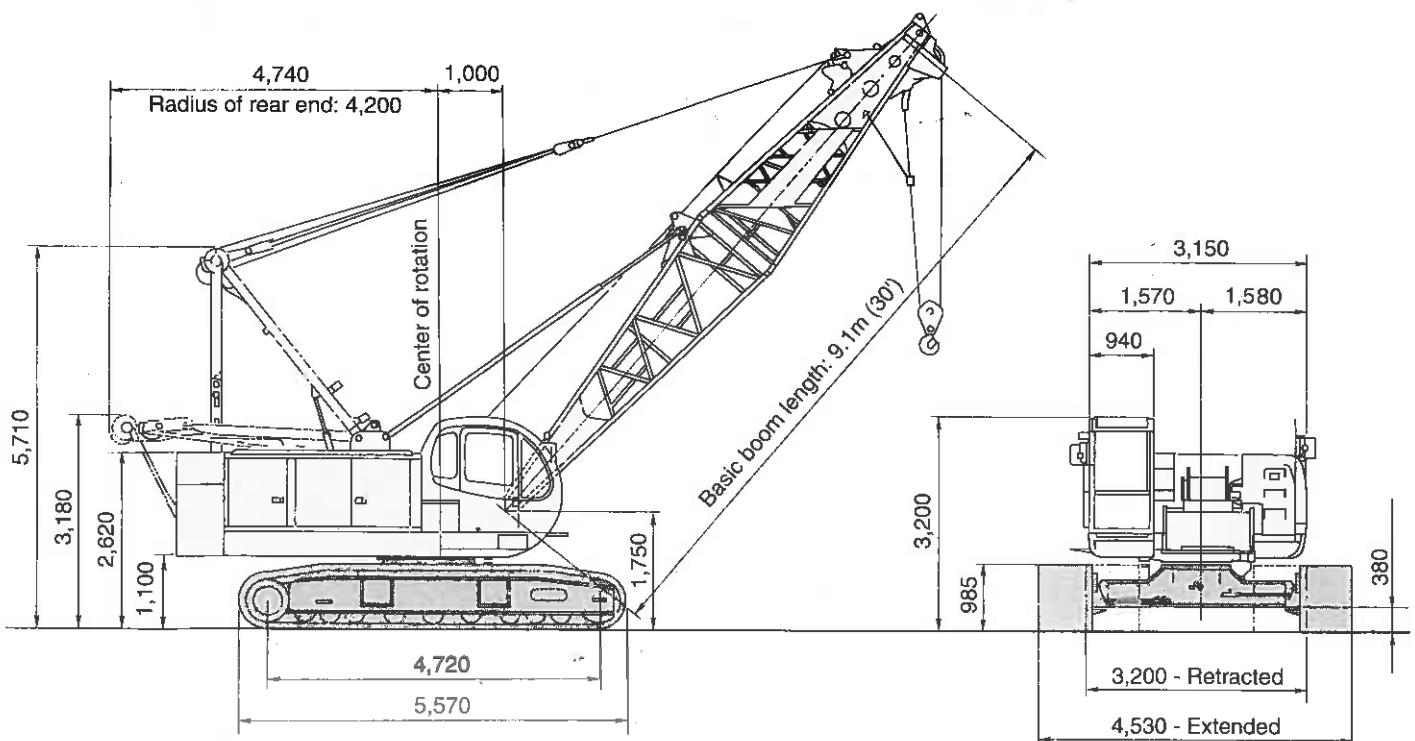

# Specifications

## Upper machinery



### Power plant

**Model** ..... Mitsubishi 6D22-T  
**Type** ..... Water-cooled, direct fuel injection, with turbocharger

**No. of cylinder** ..... 6  
**Bore and stroke** ..... 130 mm x 140 mm (5.1" x 5.5")  
**Displacement** ..... 11.15 liters  
**Rated power** ..... 230 PS (170 kW) at 1,800 rpm (JIS D1005)

**Max. torque** ..... 102 kg-m at 1,200 rpm (JIS D1005)

**Cooling system** ..... Liquid, recirculating bypass

**Starter** ..... 24 V, 5.5 kW

**Generator** ..... 24 V, 2 kW

**Cycles** ..... 4

**Radiator** ..... Plate fin type core, thermostatically controlled

**Air cleaner** ..... Dry type with replaceable paper element

**Fuel tank capacity** ..... 360 liters

**Batteries** ..... Two 12V, 170 A-hr capacity batteries, series connected

**Fuel consumption (at 1,300 rpm)** ..... 154 g/PS-h



### Hydraulic system

**Pumps:** All three variable displacement pumps are driven by heavy-duty pump drive. One of these pumps is used in the right propel circuit and hook hoist circuit, and can accommodate an optional third circuit. Another is used in the left propel circuit and hook hoist circuit. The third variable displacement pump is used in the swing circuit. In addition, one gear pumps are used in the control system and auxiliary equipment. One of these serves the clutch and brakes.

**Control:** Full-flow hydraulic control system for infinitely variable pressure to front and rear drums, boom hoist brakes and clutches. Controls respond instantly to the touch, delivering smooth function operation.

**Max. relief valve pressure:**

**Load hoist, boom hoist**

**and propel system** ..... 315 kg/cm<sup>2</sup> (4,480 psi)

**Swing system** ..... 260 kg/cm<sup>2</sup> (3,700 psi)

**Control system** ..... 80 kg/cm<sup>2</sup> (1,140 psi)

**Reservoir capacity:** 300 liters

**Cooling:** Oil-to-air heat exchanger

**Filtration:** Full-flow and bypass type with replaceable

**Electrical system:** All wiring corded for easy servicing, individual fused branch circuits.



### Boom hoisting system

Powered by a hydraulic axial piston motor through a planetary reducer.

**Brake:** A spring-set, hydraulically released multiple-disc brake is mounted on the boom hoist motor and operated through a counter-balance valve. Safety pawls (external ratchet) are fitted for locking the drum.

**Drum:** Single drum, grooved for 16mm dia. wire rope.

**Line speed:** Single line on first drum layer

Hoisting (max.) ..... 65m/min

Lowering (max.) ..... 65m/min



### Load hoist system

Powered by the hydraulic axial piston motors, driven through a planetary reducer.

**Clutches:** Internally expanding band clutches.

711 mm dia. x 102 mm wide

**Brakes:** Externally contracting band brakes, each using positive and negative actuation. 900 mm dia. x 120 mm wide with additional spring set hydraulically released brake.

Safety pawls (external ratchet) are fitted for locking the drums. Both positive and negative brake systems are available. Air cooling fins mounted on brake drum.

**Drums:** (front and rear): 462 mm P.C.D. x 522 mm wide drums, each grooved for 22 mm wire rope.

Rope capacity of 175 m working length and 278 m storage length.

**Line speed:** Single line on the first drum layer

Hoisting ..... 100/70, 50/35 m/min

Lowering ..... 100/70, 50/35 m/min



### Swing system

**Swing unit:** Powered by hydraulic axial piston motor driving spur gears through planetary reducers, the swing system provides 360°

rotation.

**Swing speed** ..... 3.7 rpm

**Swing brakes:** A spring-set, hydraulically released multiple-disc brake is mounted on swing motor.

**Swing circle:** Single-row ball bearing with an integral internally cut swing gear.

**Swing lock:** Two position pin-hole lock (manually engaged)



### Operator's cab

Totally enclosed, full-vision cab fitted with safety glass and a sliding front window. A fully adjustable, high-backed seat permits operators to set their ideal working position. A signal horn, cigarette lighter and windshield wiper are standard features.



### Controls

In front of the operator are foot pedals for front and rear drum brakes. At the operator's right are console-mounted adjustable short levers for front and rear drum control, boom hoist control lever and positive/negative break select switch for front and rear drum brakes. Beside the operator's seat on the right are two short levers for propel control. At the operator's left are: a console-mounted swing lever, an optional third drum control lever, and front and rear drum pawl control switches; switches for ignition, engine stop, a down speed adjusting knobs for front drum, rear drum, boom, and propel; Creep speed control switch for hoist is on the hoist lever. A swing brake switch and a signal horn button are on the swing lever.

**Lights:** Two front flood lights and one cab inside light

**Gauges:** Fuel, water temperature for engine, hour meter, tachometer

**Warning lamps:** Engine oil pressure, hydraulic oil pressure, battery charge, air cleaner and engine oil filter.

**Safety devices:** Function lock lever, hook over-hoist alarm and shut-off switch, boom over-hoist limit switch, boom angle indicator, signal horn, boom hoist and front and rear drum locks, swing lock, boom back stop, hook safety latch and optional load moment limiter (overload protection device) are provided.



### Gantry

Folding type, fitted with sheave frame for boom hoist reeving, lowers toward rear onto cab roof. Hydraulic lift is standard. Full up, full down positions with linkage.

### Counterweight

Two-piece stack, mounted behind the machinery compartment.

Total weight ..... 14,900 kg



### Tools

Tool set and accessories for routine machine maintenance are provided.

## Lower machinery

**Carbody:** Steel-welded carbody with axles.

**Crawler:** Crawler assemblies designed with an easy disconnect feature that allows complete individual removal from the axles. Crawler belt tension is maintained by hydraulic jack force on the track-adjusting bearing block.

**Crawler drive:** Independent hydraulic propel drive is built into each side frame, each with a hydraulic motor propelling a driving tumbler through a planetary gear box.

**Crawler brakes:** Spring-set, hydraulically released multiple-disc parking brakes are built into each propel drive.

**Steering mechanism:** A hydraulic propel system provides both skid steering (driving one track only) and counter-rotating steering (driving tracks in opposite directions).

**Track rollers:** 9 lower rollers and 2 upper rollers are fitted to each side frame, sealed and maintenance-free.

### Shoes:

Number ..... 59 each side  
Standard flat shoe width ..... 760 mm

### Max. travel speed:

High range ..... 2.2 km/h  
Low range ..... 1.4 km/h

**Max. gradeability:** 30%

## Crane attachment

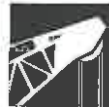

### Boom:

Welded lattice construction using tubular, high-tensile steel cords with pin connections between sections.

Max. lifting capacity	55,000 kg
Basic boom length	9.1m (30')
Max. boom length	51.8m (170')



### Jib (optional):

Welded lattice construction using tubular, high-tensile steel cords with pin connections between sections.

	Fixed jib
Max. lifting capacity	6,600 kg
Max. jib length	18.3 m (60')
Max. total length (Boom length + jib length)	42.7m (140') + 12.2 (40') 39.6m (130') + 18.3 (60')



### Hook blocks

A range of hook blocks can be specified, each with a safety latch.

Lifting capacity	55tons	45tons	32tons	19tons	6.6tons ball hook
No. of sheaves	5	3	2	1	0
Weight (kg)	650	500	500	400	160

### Diameter of wire ropes

#### Standard:

Hook hoist ..... 22 mm  
Boom hoist (12-part line) ..... 16 mm  
Boom pendants (2-part line) ..... 30 mm

#### Optional:

Jib hook hoist ..... 22 mm  
Jib back stay pendants (2-part line) ..... 20 mm

**Boom hoist reeving:** 12 parts of 16 mm dia. wire rope

**Boom backstops:** recommended for all boom lengths

### Line pull

(for crane, clamshell, diaphragm wall bucket)

	Max. permissible	Max. available
Front:	6,600 kg	17,000 kg
Rear:	6,600 kg	17,000 kg



### Weight

#### Operating weight:

Approx. 55,000 kg  
(including 9.1 m (30 ft) boom and 55 ton hook block)

**Ground pressure:** 0.71 kg/cm<sup>2</sup> with 760 mm shoes

### Notes:

- Working radius is the horizontal from the center of rotation through the center of gravity of load.
- Ratings do not exceed 78% of tipping load on the hard horizontal ground and includes weight of hook block, slings and all other load handling accessories from main boom or jib rating shown.
- Ratings shown are based on freely suspended load and make no allowance for such factors as wind effect on lifted load, out-of-level ground conditions, operating speeds or any other condition that could be detrimental to the safe operation of this equipment.
- No operation is possible in the range indicated by blank spaces in the chart.
- The actual hoistable loads using main boom must be calculated by deducting the weight of main hook, slings and all other load handling accessories etc. from the ratings shown.
- Configurations of main Boom/Jib inserts and guy cables installations must be arranged as per the instruction of the owner and operator's manual, to be provided with machine.
- Hook block weight and capacity (metric ton).

Capacity of hook	55 ton	45 ton	32 ton	19 ton	6.6 ton (ball-hook)
Weight (metric ton)	0.65	0.5	0.5	0.4	0.16

### 8. Max. hoisting load

No. of parts of line	1	2	3	4	5
Max. load (metric ton)	6.6	13.2	19.8	26.4	33.0
No. of parts of line	6	7	8	9	
Max. load (metric ton)	39.6	46.2	52.8	55.0	

- Auxiliary sheave rating is determined by deducting weight of auxiliary sheave (300kg) and weight of main hook from main boom rating. It must not exceed 6.6 tons. Minimum ratings 1.1 tons.

Jib length m (ft)	6.1 (20)	12.2 (40)	18.3 (60)	Aux. sheave
Deduct (metric ton)	1.1	1.6	2.1	0.46

- Actual hoistable loads using auxiliary sheave can be calculated by deducting weight of 6.6 ton ball-hook and weight of slings and other loads handling accessories from auxiliary sheave rating.
- Main boom rating when it is equipped with auxiliary sheave is determined by deducting the weight of the auxiliary sheave and ball-hook (460kg) from the rating for main boom without auxiliary sheave.
- Actual hoistable load with main boom being equipped with auxiliary sheave can be calculated by deducting weight of main hook, and any other slings and accessories from the main boom rating with auxiliary sheave.
- Auxiliary sheave can be attached to boom between 9.1m and 48.8 m in length.
- Maximum working radius with auxiliary sheave attached must not exceed maximum working radius of main boom. Minimum working radius is working radius of auxiliary sheave at boom angle for minimum working radius of boom.
- Do not use hook on main boom and hook on auxiliary sheave simultaneously.
- Boom should in principle be erected over front of crawlers.

### Working Ranges

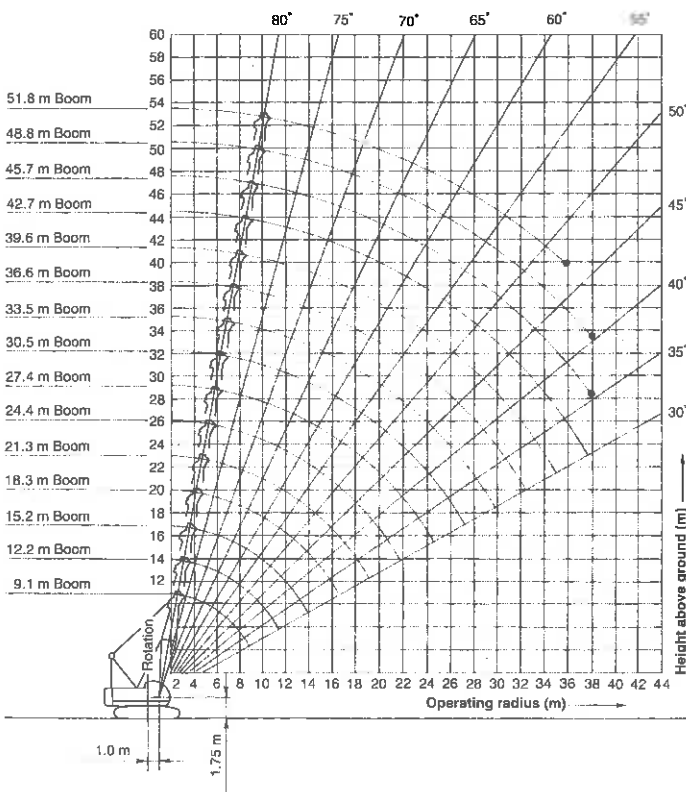

### Fixed Jib Working Range

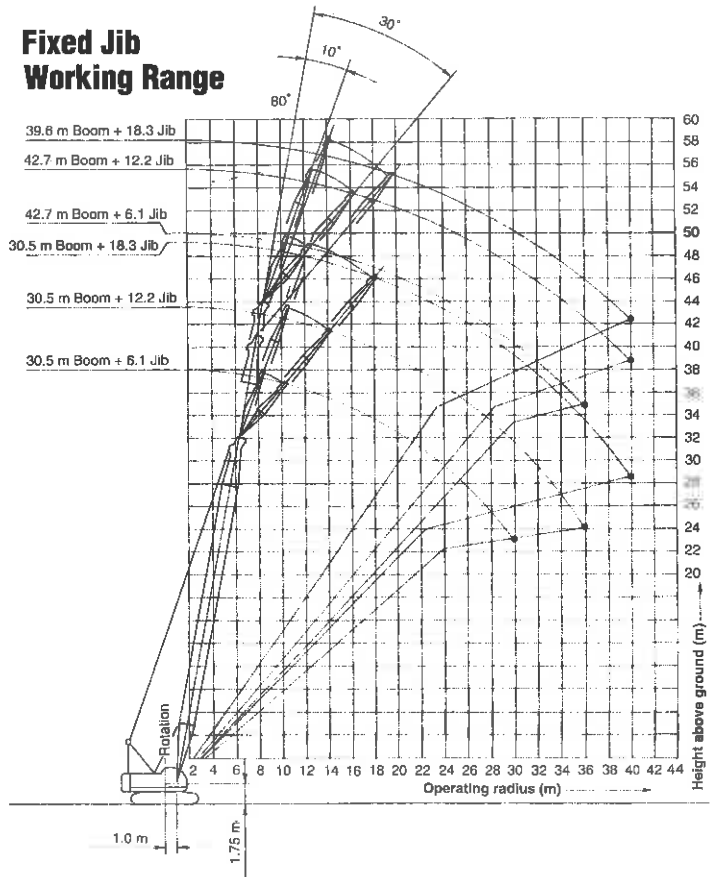

# Boom Lifting Capacities

# BM 600

Unit: metric ton

## Rated loads in metric tons for 360° working area

Crawler fully extended

Working radius m	9.1 (30)	12.2 (40)	15.2 (50)	18.3 (60)	21.3 (70)	24.4 (80)	27.4 (90)	30.5 (100)	33.5 (110)	36.6 (120)	39.6 (130)	42.7 (140)	45.7 (150)	48.8 (160)	51.8 (170)	Working radius m
3.0	55.0	55.0/3.5														3.0
3.7	55.0	55.0														3.7
4.0	50.7	50.7	50.7													4.0
4.5	44.5	44.4	44.4	44.3												4.5
5.0	38.5	38.4	38.3	38.3	37.7											5.0
5.5	32.7	32.6	32.6	32.6	32.5	31.6/5.6										5.5
6.0	28.7	28.6	28.5	28.5	28.4	28.4	27.6/6.1	24.2/6.6								6.0
7.0	22.8	22.7	22.6	22.6	22.5	22.4	22.4	22.3	21.3/7.2	19.2/7.7						7.0
8.0	18.9	18.8	18.6	18.6	18.5	18.5	18.4	18.4	18.3	18.2	17.4/8.2	15.8/8.7				8.0
9.0	16.1	15.9	15.8	15.8	15.7	15.6	15.6	15.5	15.4	15.4	15.3	15.2	13.2/9.3	13.2/9.8		9.0
10.0	15.9/9.1	13.8	13.7	13.6	13.5	13.5	13.4	13.4	13.3	13.2	13.1	13.1	13.0	12.9	11.8/10.3	10.0
12.0		11.2/11.7	10.7	10.7	10.6	10.5	10.4	10.4	10.3	10.2	10.1	10.0	10.0	9.9	9.8	12.0
14.0			8.8	8.7	8.6	8.5	8.4	8.4	8.3	8.2	8.1	8.0	8.0	7.9	7.8	14.0
16.0			8.5/14.4	7.3	7.2	7.1	7.0	7.0	6.9	6.8	6.7	6.6	6.5	6.5	6.3	16.0
18.0				6.8/17.0	6.2	6.1	6.0	5.9	5.8	5.7	5.6	5.5	5.5	5.4	5.3	18.0
20.0					5.4/19.7	5.3	5.2	5.1	5.0	4.9	4.8	4.7	4.6	4.5	4.4	20.0
22.0						4.6	4.5	4.4	4.3	4.2	4.1	4.0	3.9	3.9	3.7	22.0
24.0						4.5/22.3	4.0	3.9	3.8	3.7	3.6	3.5	3.4	3.3	3.2	24.0
26.0							3.8/24.9	3.4	3.3	3.2	3.1	3.0	2.9	2.8	2.7	26.0
28.0								3.1/27.6	3.0	2.9	2.8	2.7	2.6	2.5	2.4	28.0
30.0									2.6	2.5	2.4	2.3	2.2	2.1	2.0	30.0
32.0									2.5/30.2	2.3	2.2	2.1	2.0	1.9	1.8	32.0
34.0										2.1/32.9	1.9	1.8	1.7	1.6	1.5	34.0
36.0											1.7/35.5	1.5	1.4	1.3	1.1	36.0
38.0												1.3	1.2	1.1		38.0

Note: Ratings inside shown in   are determined by the strength the boom or other structural components.

## Boom Component Chart

Boom length m (ft)	Boom arrangement
9.1 (30)	Base-Tip
12.2 (40)	Base-A-Tip
15.2 (50)	Base-B-Tip, Base-A-A-Tip
18.3 (60)	Base-A-B-Tip, Base-C-Tip
21.3 (70)	Base-A-C-Tip, Base-B-B-Tip, Base-A-A-B-Tip
24.4 (80)	Base-B-C-Tip, Base-A-B-B-Tip, Base-A-A-C-Tip, Base-C-C-Tip
27.4 (90)	Base-A-B-C-Tip, Base-B-B-B-Tip, Base-A-A-B-B-Tip, Base-A-A-B-B-Tip
30.5 (100)	Base-B-B-C-Tip, Base-A-C-C-Tip, Base-A-A-C-C-Tip, Base-A-A-B-C-Tip

Boom length m (ft)	Boom arrangement
33.5 (110)	Base-B-C-C-Tip, Base-A-B-B-C-Tip, Base-A-A-B-B-C-Tip, Base-A-A-C-C-Tip
36.6 (120)	Base-A-B-C-C-Tip, Base-A-A-B-B-C-Tip, Base-B-B-B-C-Tip
39.6 (130)	Base-B-B-C-C-Tip, Base-A-A-B-C-C-Tip
42.7 (140)	Base-A-A-B-B-C-C-Tip, Base-B-B-B-C-C-Tip
45.7 (150)	Base-A-A-B-B-C-C-Tip, Base-B-B-B-C-C-Tip
48.8 (160)	Base-A-B-B-B-C-C-Tip
51.8 (170)	Base-A-A-B-B-B-C-C-Tip

Base = 5.1m (17'), Tip = 4.0m (13')  
 Inserts: A = 3.0 m (10'), B = 6.1 m (20'), C = 9.1 m (30')

# Fixed Jib Lifting Capacities

# BM 600

Unit: metric ton

## Jib Rated loads in metric tons for 360° working area (Jib offset angle 10°/with main hook) Crawler fully extended

Boom Length m (ft)	30.5 (100)			33.5 (110)			36.6 (120)			39.6 (130)			42.7 (140)	
Jib Length m (ft)	6.1 (20)	12.2 (40)	18.3 (60)	6.1 (20)	12.2 (40)	18.3 (60)	6.1 (20)	12.2 (40)	18.3 (60)	6.1 (20)	12.2 (40)	18.3 (60)	6.1 (20)	12.2 (40)
Radius (m)														
9	6.6			6.6										
10	6.6			6.6			6.6			6.6				
12	6.6	6.6	4.5	6.6	6.6	4.5	6.6	6.6		6.6	6.6		6.6	
14	6.6	6.6	4.5	6.6	6.6	4.5	6.6	6.6	4.5	6.6	6.6	4.5	6.6	6.6
16	6.6	6.6	4.5	6.6	6.6	4.5	6.6	6.6	4.5	6.6	6.6	4.5	6.5	6.3
18	5.7	6.0	4.5	5.6	5.9	4.5	5.5	5.8	4.5	5.4	5.7	4.5	5.3	5.6
20	4.8	5.1	4.5	4.7	5.0	4.5	4.6	4.9	4.5	4.5	4.8	4.5	4.4	4.7
22	4.1	4.4	4.5	4.0	4.3	4.4	3.9	4.2	4.3	3.8	4.1	4.2	3.7	4.0
24	3.6	3.8	3.9	3.4	3.7	3.8	3.4	3.6	3.7	3.2	3.5	3.6	3.1	3.4
26	3.1	3.3	3.4	2.9	3.2	3.3	2.9	3.1	3.2	2.7	3.0	3.1	2.6	2.9
28	2.7	2.9	3.0	2.5	2.8	2.9	2.4	2.7	2.8	2.3	2.6	2.7	2.1	2.4
30	2.3	2.5	2.7	2.1	2.4	2.5	2.0	2.3	2.5	1.8	2.2	2.3	1.7	2.0
32	1.9	2.2	2.4	1.8	2.1	2.2	1.7	2.0	2.1	1.5	1.8	1.9	1.4	1.7
34		1.9	2.1	1.5	1.7	1.9	1.3	1.6	1.8	1.2	1.5	1.6		1.3
36		1.6	1.8	1.2	1.5	1.6	1.1	1.4	1.5		1.2	1.3		1.1
38		1.4	1.6		1.2	1.4		1.1	1.3			1.1		
40			1.3			1.2								

Note: Ratings inside shown in  are determined by the strength of the boom or other structural components.

## Jib Rated loads in metric tons for 360° working area (Jib offset angle 30°/with main hook) Crawler fully extended

Boom Length m (ft)	30.5 (100)			33.5 (110)			36.6 (120)			39.6 (130)			42.7 (140)	
Jib Length m (ft)	6.1 (20)	12.2 (40)	18.3 (60)	6.1 (20)	12.2 (40)	18.3 (60)	6.1 (20)	12.2 (40)	18.3 (60)	6.1 (20)	12.2 (40)	18.3 (60)	6.1 (20)	12.2 (40)
Radius (m)														
12	6.6			6.6			6.6			6.6				
14	6.6			6.6			6.6			6.6			6.6	
16	6.6	5.0		6.6	5.0		6.6	5.0		6.6	5.0		6.4	
18	5.9	5.0	3.2	5.8	5.0	3.2	5.8	5.0		5.7	5.0		5.6	4.4
20	5.0	5.0	3.2	4.9	5.0	3.2	4.8	5.0	3.2	4.7	5.0	3.2	4.7	4.3
22	4.3	4.7	3.2	4.2	4.6	3.2	4.1	4.5	3.2	4.0	4.5	3.2	3.9	4.1
24	3.7	4.1	3.2	3.6	4.0	3.2	3.5	3.9	3.2	3.4	3.8	3.2	3.3	3.7
26	3.2	3.5	3.2	3.1	3.4	3.2	3.0	3.4	3.2	2.9	3.3	3.2	2.8	3.2
28	2.7	3.1	3.2	2.6	3.0	3.2	2.6	2.9	3.2	2.4	2.8	3.1	2.3	2.8
30	2.4	2.7	2.9	2.2	2.6	2.8	2.1	2.5	2.8	2.0	2.4	2.7	1.9	2.3
32		2.4	2.6	1.8	2.3	2.5	1.7	2.2	2.4	1.6	2.1	2.3	1.5	1.9
34		2.1	2.3		1.9	2.2	1.4	1.8	2.1	1.3	1.7	2.0	1.2	1.6
36		1.8	2.0		1.6	1.9		1.5	1.8		1.4	1.7		1.3
38			1.8		1.3	1.6		1.3	1.5		1.1	1.4		
40			1.5			1.4			1.3			1.2		

Note: Ratings inside shown in  are determined by the strength of the boom or other structural components.

## Jib Component Chart

Jib length m (ft)	Jib arrangement
6.1 (20)	Base-Tip
12.2 (40)	Base-A-Tip
18.3 (60)	Base-A-A-Tip

Base = 3.0m(10'), Tip = 3.0m(10')  
 Inserts: A = 6.10 m (20')

### Note:

- Jib can be fitted to main boom between 30.5 m (100') and 42.7 m (140') in length.
- Fitting a jib requires an insert boom with lugs.
- Actual hoistable loads using jib can be calculated by deducting the total weight of jib hook and slings and all other load handling accessories from jib ratings. (Weight of main hook does not need to be deducted.)

## Clamshell ratings in metric tons for 360° working area

Crawler fully extended

Boom length	m (ft)	A	9.1 (30)				12.2 (40)				15.2 (50)				18.3 (60)				
Boom angle	(°)	θ	35	45	55	65	35	45	55	65	35	45	55	65	35	45	55	65	
Operating radius	(m)	R	8.7	7.7	6.5	5.2	11.2	9.9	8.3	6.5	13.7	12.0	10.0	7.7	16.2	14.2	11.8	9.0	
Dumping height (m)	Bucket capacity (m³)	H	0.8	0.9	2.2	3.2	4.1	2.7	4.3	5.7	6.9	4.4	6.5	8.2	9.6	6.2	8.6	10.7	12.4
			1.0	0.9	2.2	3.2	4.1	2.7	4.3	5.7	6.9	4.4	6.5	8.2	9.6	6.2	8.6	10.7	12.4
			1.2	0.5	1.8	2.8	3.7	2.3	3.9	5.3	6.5	4.0	6.1	7.8	9.2	5.8	8.2	10.3	12.0
			1.6	0.6	1.9	2.9	3.8	2.4	4.0	5.4	6.6	4.1	6.2	7.9	9.3	5.9	8.3	10.4	12.1
Boom point height	(m)	h	6.7	8.0	9.0	9.9	8.5	10.1	11.6	12.7	10.2	12.3	14.0	15.4	12.0	14.4	16.5	18.2	
Rated load	(ton)		5.5																

**Note:**

- Working radius is the horizontal distance between the center of rotation and the bucket's center of gravity.
- Total weight of bucket and materials must not exceed rated load.  
Bucket capacity (m³) x specific gravity of material (ton/m³) + bucket weight (ton) ≤ rated load
- Rated load must not be exceeded, even when using bucket of different capacity for separate task.
- Bucket unit weight must not exceed 3.1 tons. Bucket weight must also be decreased according to operating cycle and bucket lowering height.
- Rated loads are determined by degree of stability. During simultaneous operations of boom and swing, rapid acceleration or deceleration must be avoided. Particular care is required with long boom lengths.
- The 1.6 m³ bucket is for loading operations.

## Working Range

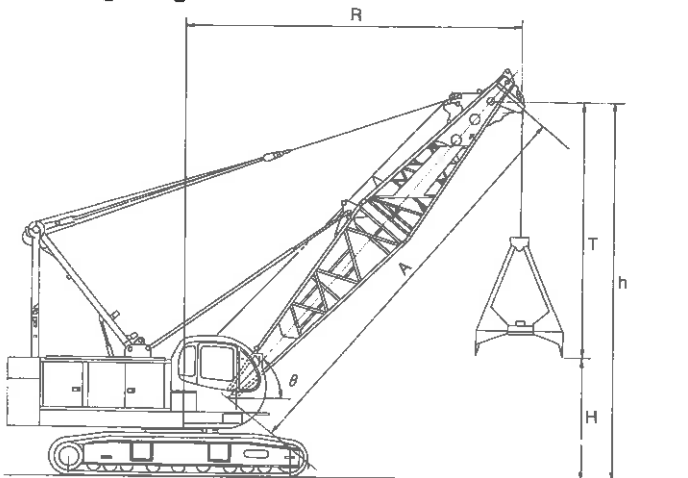

## Clamshell Bucket

Bucket capacity (m³)	Approximate weight (ton)	Bucket clearance (m)
		T
0.8	2.1	3.3
1.0	2.5	3.3
1.2	3.1	3.7
1.6	2.8	3.6

# Dragline

## Dragline ratings in metric tons for 360° working area

Crawler fully extended

A	Boom length m (ft)	12.2 (40)			15.2 (50)			18.3 (60)		
F	Boom angle (°)	30	40	50	30	40	50	30	40	50
D	Dumping radius (m)	12.0	10.9	9.4	14.7	13.2	11.3	17.3	15.5	13.3
E	Max. dumping height (m)	5.1	6.8	8.3	6.6	8.8	10.7	8.1	10.8	13.0
G	Max. digging reach (m)	16.8	15.3	13.3	20.2	18.3	15.7	23.6	21.3	18.2
H	Max. digging depth (m)	9.4	8.2	6.6	12.0	10.5	8.6	11.1	8.5	6.2
	Rated load (ton)	6.6	6.6	6.0	4.9	6.3	6.6	4.0	4.8	6.0

## Dimensions

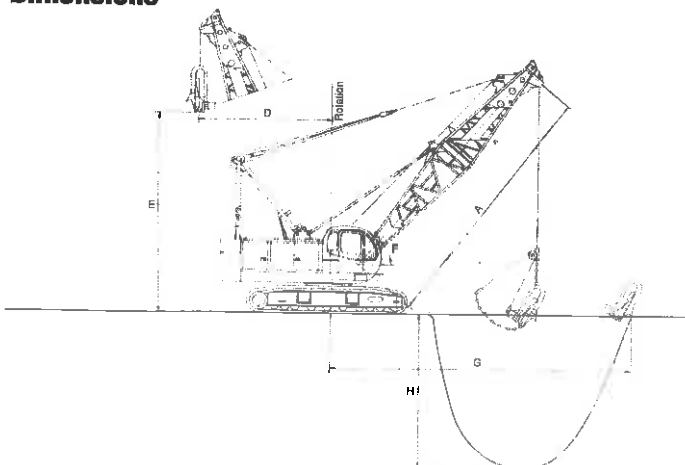

**Note:**

- Dimension G may vary considerably depending on digging conditions and the skill of the operator.
- Dimension H may vary depending on digging material.
- Above ratings are for combined weight of bucket, accessories, and material.
- Maximum boom length recommended for dragline operation is 18.3m (60').
- A 9.9-ton counterweight should be attached for dragline operation.
- Maximum allowable bucket weight is 2.1 tons.
- Maximum allowable digging bucket size:  
Heavy-duty type: 1.5 m³  
Light-duty type: 2.0 m³

# KOBELCO

## HEAVY DUTY BASE MACHINE FOR FOUNDATION WORK BM 600

Address inquiries to:

NOTE: Due to a number of countries, specifications are subject to change without advance notice.

# CIMALEV

1, Impasse des Rossignols - 95390 SAINT-PRIX (FR)  
Tél. : 33 (0)1 34 27 91 40 - Fax : 33 (0)1 39 59 74 00  
E-mail : CIMALEV@aol.com

LOCATEL  
RIGID  
KOBELCO

This catalog is printed on recycled paper.  
950203TF Printed in Japan